

Color Video Cameras

MODELS KP-D51/D50

OPERATION MANUAL

Please read this operation manual carefully for proper operation, and keep it for future reference.

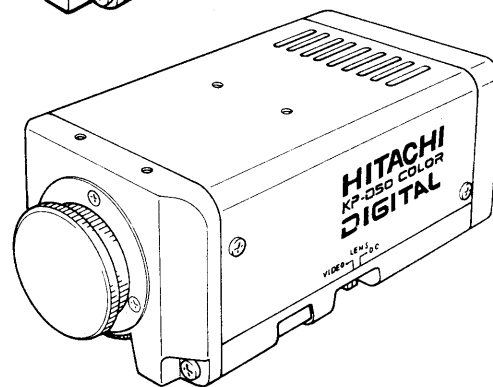
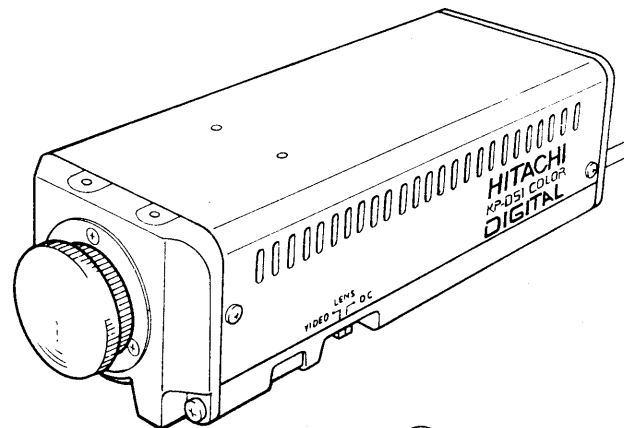

 **Hitachi Denshi, Ltd.**

Table of contents

CAUTION FOR SAFE OPERATION	A	Flange focal distance adjustment	15
IMPORTANT NOTICE	F	Installation of camera	16
General	1	Description on setting menus	18
Features	1	Configuration of setting menus	18
Operating considerations	2	Setting procedures	19
Phenomena inherent to		Main setting menu	20
CCD imaging device	3	Character display setting menu	21
Name and function of each section	4	Light control setting menu	23
Connection	6	AGC setting menu	28
Connection of video output	6	White balance control setting menu	30
Connection of external sync input	6	Shutter speed setting menu	33
Connection of DC power supply		Sync mode (phase adjustment)	
(KP-D50 only)	7	setting menu	34
Connection of RGB outputs(KP-D50 only)	7	Special setting menu	36
Connection of HD/VD inputs(KP-D50 only)	8	Color temperature and	
Connection of Y/C outputs(KP-D50 only)	9	white balance adjustment	38
Connection of D-sub(9-pin) connector		Remote operation	39
(KP-D50 only)	10	Major specifications	41
Lens	12	Accessories	44
Recommended lenses	12	Optional accessories	44
Note on lens selection	13		
Installation of CS-mount lens	13		
Lens selector switch	14		
Use of lens connector	14		

General

The Hitachi KP-D50/D51 are 1/2" CCD color cameras using a digital signal processing circuit.

Features

● High sensitivity

Minimum illumination is 2 lx(f 1.2) thanks to the CCD with micro lenses and a low noise circuit.

● High resolution

Horizontal resolution of 470 TV lines NTSC (460 TV lines PAL) is achieved by using a CCD having the 380,000 NTSC (440,000 PAL) effective pixels.

● High picture quality

- * Digital signal processing LSI
- * Contour compensation by digital technology and 2H vertical enhancer
- * Dynamic range improved by contrast correction processing (black stretch and white suppression)

● Various functions

- * Backlight correction function (auto or manual setting)
- * Auto tracking white balance
- * Electronic shutter function (up to 1/10000 s)

- * Auto electronic shutter function, and auto electronic shutter + auto iris function
- * Text display function (character generator function)
- * Internal/external synchronization function
- * Genlock (KP-D51)
- * HD/VD pulses (KP-D50)
- * RGB outputs (KP-D50 only)
Image processing regarding colors can be made by using RGB signal outputs.
- * Y/C outputs (KP-D50 only)
A sharp, clear picture is obtained, because the luminance (Y) signal and the chrominance (C) signal are delivered separately.

Operating considerations

Power supply

Be sure to use the power source specified in the Major Specifications.

- Before plugging or unplugging a connector, be sure to turn off power.
To plug or unplug a connector, be sure to hold the connector section.
- Note that it will take several seconds until a picture is displayed on the monitor after power on.

Handling

- Do not attempt to remove cover.
- When installing or removing a lens, be sure to use care that water or dust does not enter the inside of the camera.

Installing and storage

Avoid installing or storing the camera in the following environments.

- Environments exposed to direct sunlight, rain or snow
- Environments where combustible or corrosive gas exists
- Excessively warm or cold environment (Operating ambient temperature: -10 to 50°C)
- Humid or dusty environment
- Place subjected to excessive vibration or shock
- Environment exposed to strong electric or magnetic field

- Do not aim the camera lens at the sun.
- Do not shoot strong light or a scene including strong light.

When such a scene is shot, vertical trailings will appear. However, this is not due to failure.

In case strong light enters the camera through the lens, partial deterioration in picture quality will result.

To obtain stable performance for long time

When the camera is used continuously for long time under high ambient temperature, the inside electrical parts become deteriorated, resulting in shortening its life.

To use the camera continuously for long time, the highest temperature must be below 40°C.

Cleaning

- Use a blower or a lens brush to remove dusts on the lens or the optical filter.
- Wipe dirt on the case off with dry soft cloth. If dirt is hardened, wipe them off with cloth moistened with neutral detergent liquid; wipe the cover with dry cloth.
- Do not use benzine, thinner, alcohol, liquid cleaner or spray-type cleaner.

Phenomena inherent to CCD imaging device

Following are the phenomena inherent to a CCD imaging device, and not defects

1) Smear and blooming

When strong light (lamp, fluorescent lamp, reflected light, etc.) is shot, pale bands are displayed vertically above and below the light.

In this case, change the angle of the camera so that such strong light does not enter the camera through the lens.

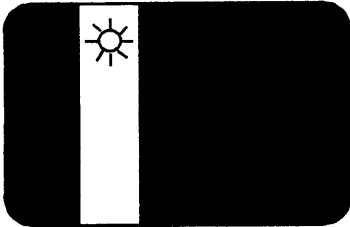

2) Fixed pattern noise

When the camera is operated in a high temperature, fixed pattern noise may appear on the entire screen.

3) Moire

When fine patterns are shot, moire may be displayed.

4) Burning

When excessively intense light comes to the CCD for a long time, the spectral filter in the CCD pixel may be deteriorated, and the color of the corresponding portion may change. Avoid using the camera under such condition.

Name and function of each section

KP-D51

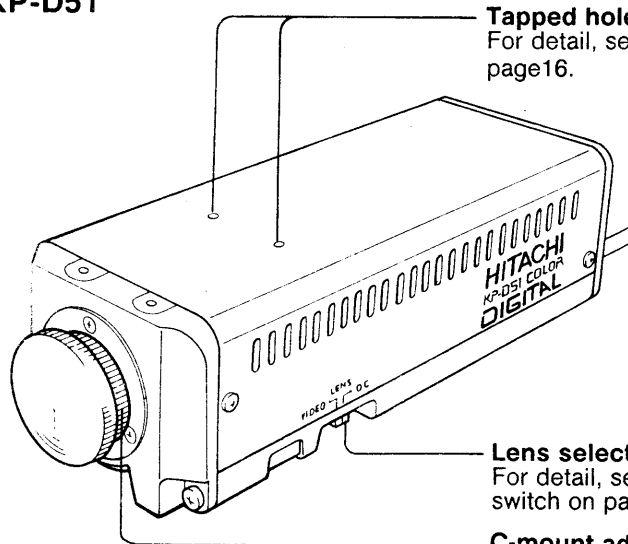

Tapped hole for camera mount adaptor
For detail, see Installation of camera on page16.

Lens selector switch
For detail, see LENS selector switch on page14.

C-mount adaptor
For detail, see lens mount on page 13.

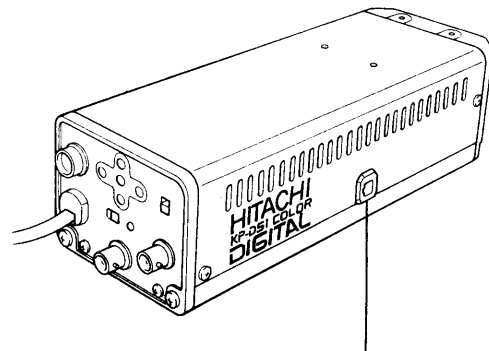

Lens connector
Connect a lens cable when an auto iris lens is used.

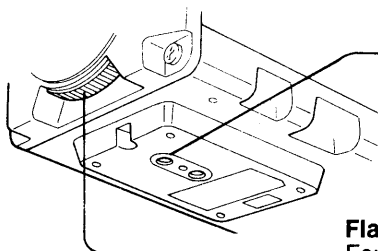

Tapped hole for camera mounting screw
1/4"-20UNC (depth:7.5mm)

Flange focal distance adjustment ring
For detail, see Flange focal distance adjustment on page 15.

Connection

• Connection of video output

Connect the video output of the camera to the video input connector of the equipment to be connected. When more than one video monitor is looped through, set the 75Ω termination switch of the final monitor to ON.

Select a coaxial cable, considering the length between the camera and the connected equipment. Approximate maximum cable length that ensures a picture with less deterioration in quality is as follows.

Approximate maximum cable length that ensures a picture with less deterioration in quality is as follows.

- 3C-2V ... 150m
- 5C-2V ... 200m
- 7C-2V ... 300m
- 10C-2V ... 400m

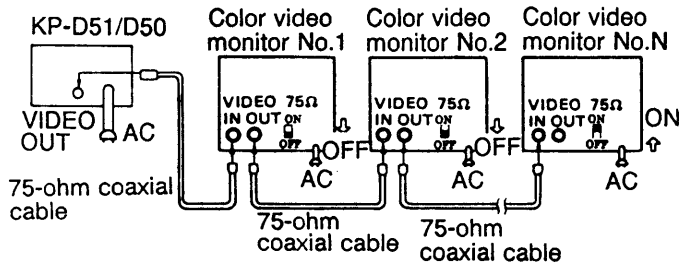

• Connection of external sync Input (KP-D51 only)

Connect a black burst signal (B.B.) or a composite video signal (VBS) to the external sync input connector, the external synchronization mode is established.

When more than one camera is genlocked in loop-through mode, set the 75Ω termination switch of the final camera to ON.

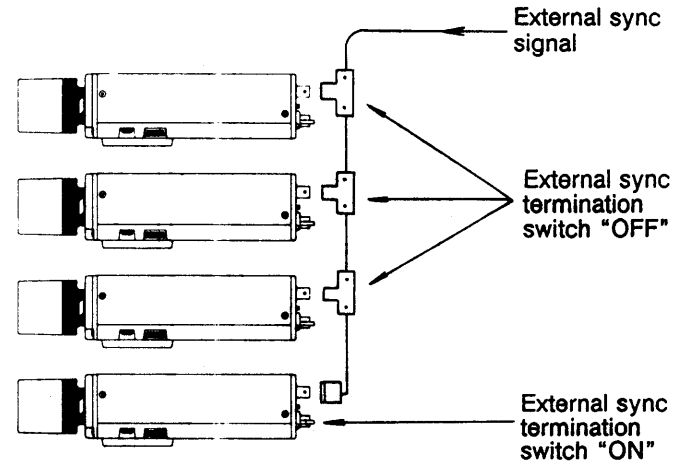

• Connection of DC power supply (KP-D50 only)

Use a DC power supply rated $12V \pm 0.6V$, 1A or more. Connect wires to the supplied power input plug as shown below, and then, connect the camera and the DC power supply, using the plug.

Caution: Prior to turning on the power switch, be sure to check that the polarities of the power supply are correct.

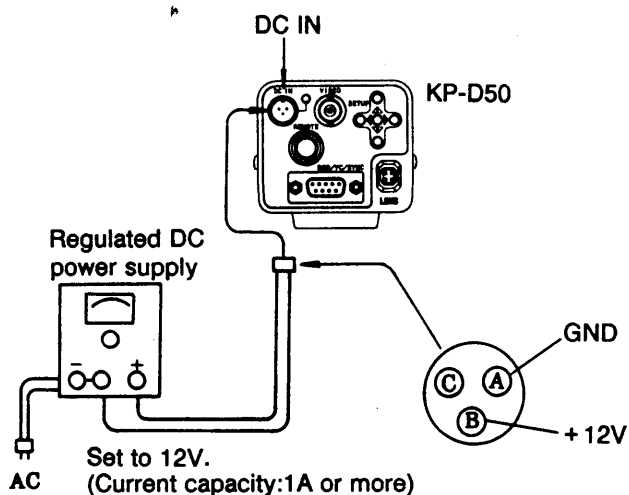

Pin connection of DC power plug

Pin	Signal
A	GND
B	+12V
C	NC

Pin arrangement Viewed from rear

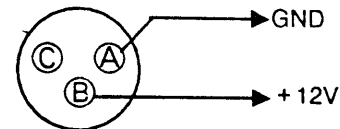

• Connection of video output connector (KP-D50 only)

Connect the video output of the camera to the video input connector of the equipment to be connected. When more than one video monitor is looped through, set the 75Ω termination switch of the final monitor to ON.

• Connection of RGB outputs (KP-D50 only)

Connect the camera to an RGB type color monitor or an image processing system as shown below, using the RGB cable as described in Connection of D-sub (9-pin) connector on page 10 or the cable with optional RGB output plug.

(Connection to color monitor)

When a color monitor energized by supplying the G signal containing a 0.3Vp-p sync signal is used, set the G-OUT SYNC switch on the RGB unit in the camera to ON. In this case, the wiring of the sync signal is not needed. The G-OUT SYNC switch is set to OFF at factory.

(Connection to image processing system)

When a sync signal is not needed for the G signal, set the G-OUT SYNC switch to OFF.

Connection in RGB output mode or external HV/VD mode

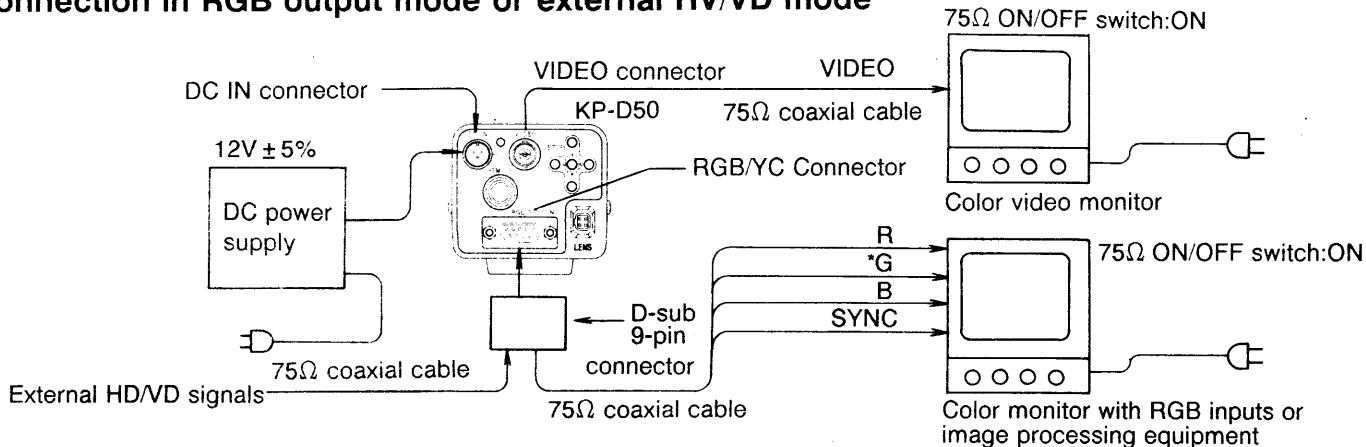

- * When a color monitor which is genlocked by applying a 0.3Vp-p SYNC to the G signal is used, set the G-OUT SYNC switch on the RGB unit inside camera to ON. In this case, wiring to the SYNC output is not needed.
- * When the camera is connected to image processing equipment and the SYNC signal is not needed for the G signal, set the G-OUT SYNC switch to OFF.

HD/VD inputs

HD and VD shall be in the relationship of 2:1 interlacing.

HD: Negative polarity, $4.0 \pm 0.5\text{Vp-p}/75\text{ ohms}$
 Frequency: $15,734 \pm 0.5\text{Hz}$ (PAL: $15,625 \pm 0.5\text{Hz}$)

VD: Negative polarity, $4.0 \pm 0.5\text{Vp-p}/75\text{ ohms}$
 A 75-ohm terminating resistor is provided in the camera.
 The timing of HD and VD between an odd field and an even field shall be as shown below.

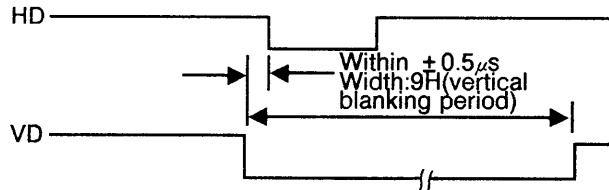

• Connection of Y/C outputs (KP-D50 only)

When the Y/C signals are connected to a VTR, color monitor or image processing system, set the RGB/YC selector switch on the RGB unit in the camera to YC. This switch is set to RGB at factory.

A sync signal is added to the Y signal and this sync signal cannot be removed. Set the G-OUT SYNC switch on the RGB unit to OFF.

Connect each equipment as shown below, referring to Connection of D-sub (9-pin) connector on page 10.

Connection in YC output mode

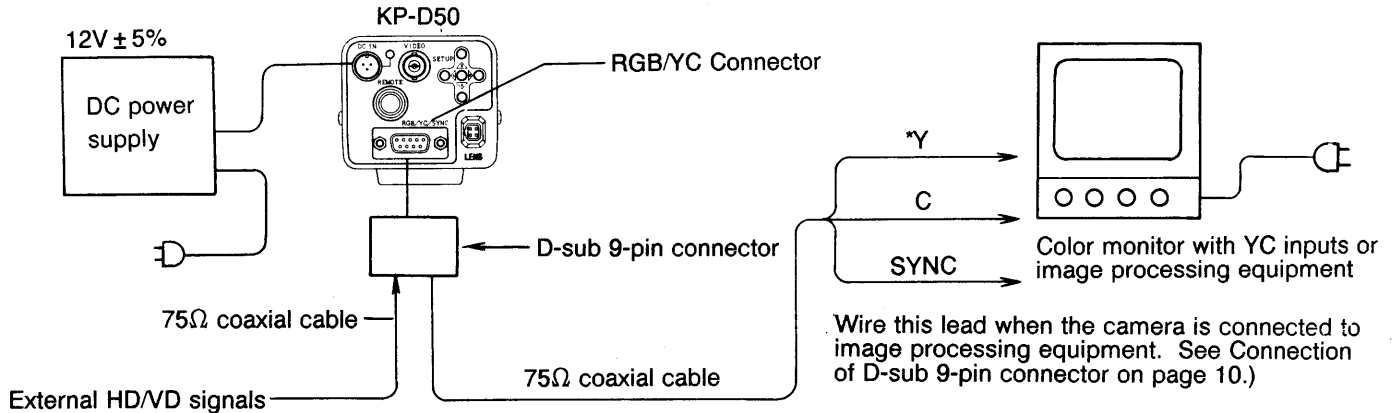

Connection of D-sub (9-pin) connector (KP-D50 only)

The signal delivered from the D-sub connector is set to the RGB signals at factory. The signal can be switched to the Y/C signals by the RGB/YC selector switch on the RGB unit in the camera. Though a sync signal is not added to the G signal, it can be added by switching the G-OUT SYNC switch on the RGB unit signal at factory.

Pin No.	RGB output	YC output	Impedance
1	GND ✕	GND	—
2	GND ✕	GND	—
3	R output ✓	Video (VBS) output*	75Ω
4	✓ G output(SYNC or no SYNC)	Y output (SYNC)	75Ω
5	✕ B output	C output	75Ω
6	Video(VBS) output* ✕	Video (VBS) output*	75Ω
7	SYNC output ✕	SYNC output	75Ω
8	HD input	HD input	75Ω
9	VD input	VD input	75Ω

Caution: When the BNC connector or the video output marked * is used independently, use a 75-ohm terminating resistor. As the video output circuit for pin 6 is the same circuit as the video output circuit of the BNC connector, do not use the both video output at the same time.

When the video output on pin 3 is terminated in the Y/C output mode, do not use the video signal on pin 6 or the video output of the BNC connector.

**D-sub 9pin connector
Pin arrangement**

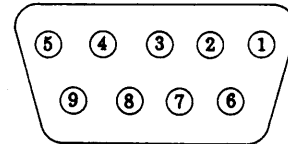

Viewed from rear

RGB/YC and G-out SYNC switch positions and setting method (For service person only)

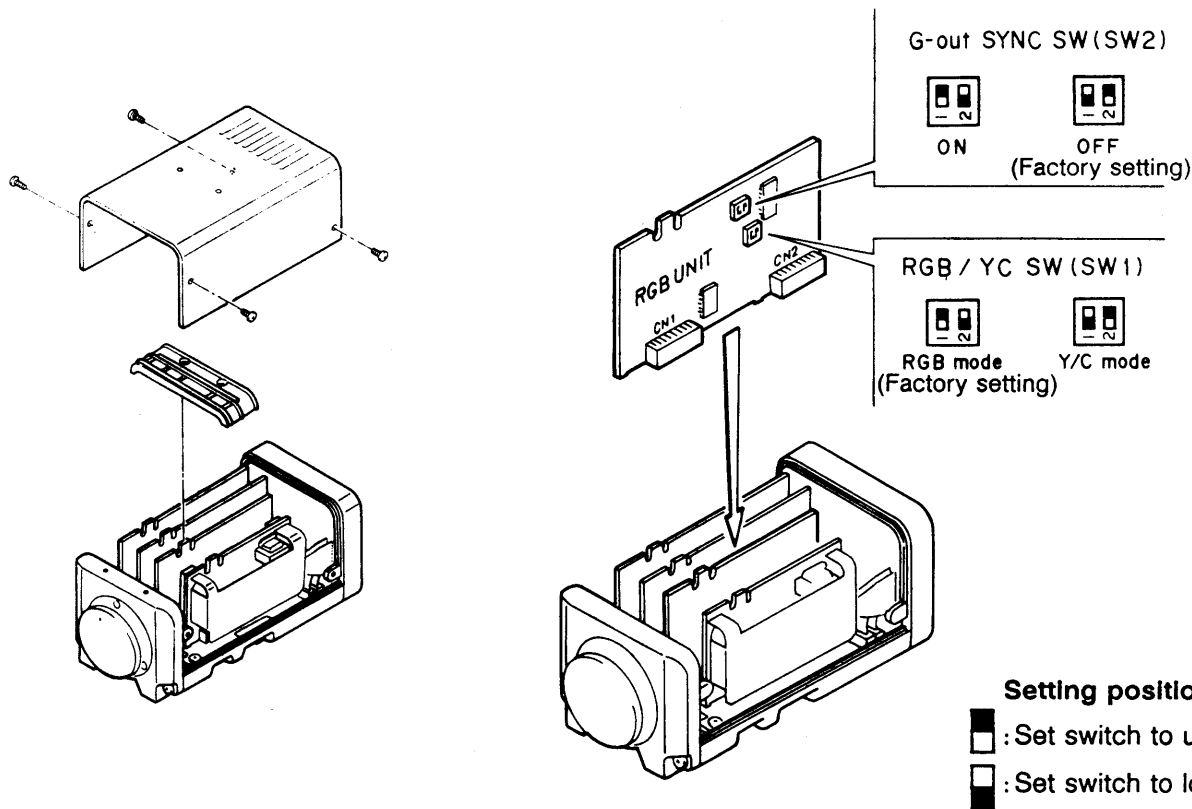

Lens

Recommended lenses

To demonstrate the full performance of the camera, select a lens from the following recommended lenses.

Type	Type name	Specification	Lens mount
Fixed iris	HS316	3.7 mm, f1.6	CS-mount
	H416	4.2 mm, f1.6	C-mount
	H612A	6 mm, f1.2	C-mount
	HS614A	6 mm, f1.4	CS-mount
	H1212A	12 mm, f1.2	C-mount
Auto-iris	HS1214C	12 mm, f1.4	CS-mount
	H416EX-2	4.2 mm, f1.6	C-mount
	H316HX	3.7 mm, f1.6	CS-mount
	HS316GX	3.7 mm, f1.6	CS-mount
	※HS316GX(HJ)	3.7 mm, f1.6	CS-mount
	H612AEX-2	6 mm, f1.2	C-mount
	H614HX	6 mm, f1.4	CS-mount
	HS614GX	6 mm, f1.4	CS-mount
	※HS614GX(HJ)	6 mm, f1.4	CS-mount
	H1212AEX-2	12 mm, f1.2	C-mount
	H1214CHX	12 mm, f1.4	CS-mount
	HS1214GX	12 mm, f1.4	CS-mount
	※HS1214GX(HJ)	12 mm, f1.4	CS-mount

Note: The auto-iris lenses marked with ※ require a DC control voltage.

Note on lens selection

- 1) Observe the following condition for the dimension of the lens mounting section.

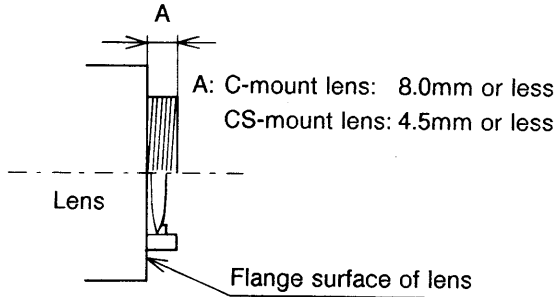

In case the above condition is not observed, the inside of the camera may be damaged.

- 2) Do not use a lens heavier than the camera body itself.

If a lens is heavier than the camera, the camera is not balanced, resulting in possible damage.

Caution:

If it is needed to use a lens heavier than the camera body, be sure to fix the lens itself on a support.

Installation of CS-mount lens

Before shipment, the C-mount adaptor for a C-mount lens is provided for the camera. When using a CS-mount lens, remove the C-mount adaptor by turning it counterclockwise.

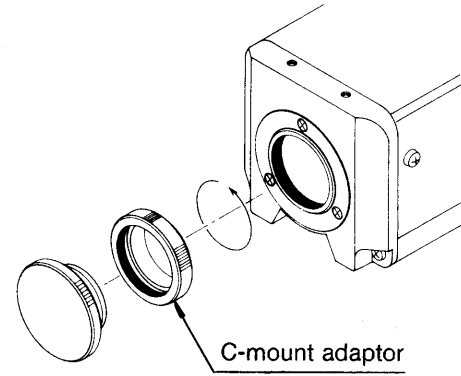

Store the removed C-mount adaptor for future use.

Lens selector switch

Switch the lens selector switch appropriately according to the lens to be used.

VIDEO : Set to **VIDEO** when a lens to which a video signal is delivered is used.

DC : Set to **DC** when a lens to which a DC control voltage is delivered is used.

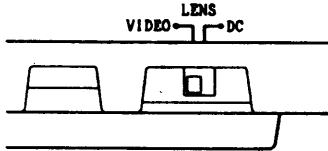

Use of lens connector

When an auto-iris lens is used, connect the lens cable to the supplied lens plug as illustrated below.

For the combination of the signals in the lens cable and wire colors, see the operation manual of the used lens.

- Lens having an iris amplifier
(Set the lens selection switch to **VIDEO**.)

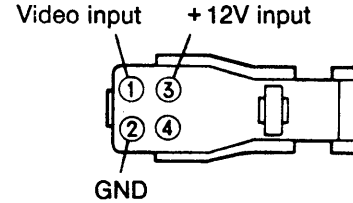

- Lens having no iris amplifier
(Set the lens selection switch to **DC**.)

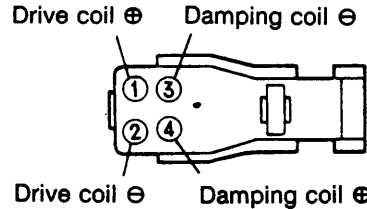

After connecting the lens plug to the tip of the lens cable, insert the plug into the lens connector [LENS] on the side of the camera.

Flange focal distance adjustment

When the picture is out of focus after a lens is replaced, or when the picture is out of focus at the telephoto and wide positions, adjust the flange focal distance.

To adjust the flange focal distance, take the following procedure.

1. In case of fixed-focus lens

Set the focus ring of the lens to the infinite position and shoot an object more than 20 meters away, then rotate the flange focal distance adjustment ring in the direction of N or F so that the picture becomes in focus.

2. In case of zoom lens

1) Set the zoom lens to the telephoto position and shoot an object more than 3 meters away. Then, rotate the focus ring appropriately so that the picture becomes in focus.

2) Set the zoom lens to the wide position and rotate the flange focal distance adjustment ring, taking care that the focus ring does not move. Repeat the above steps 1) and 2) appropriately so that the picture becomes in focus at the telephoto and wide positions.

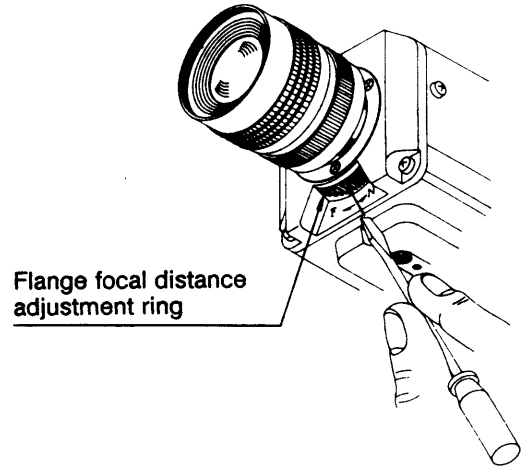

Installation of camera

To secure the camera to the hanging bracket, install the optional adaptor TA-231 on the top of the camera as illustrated below.

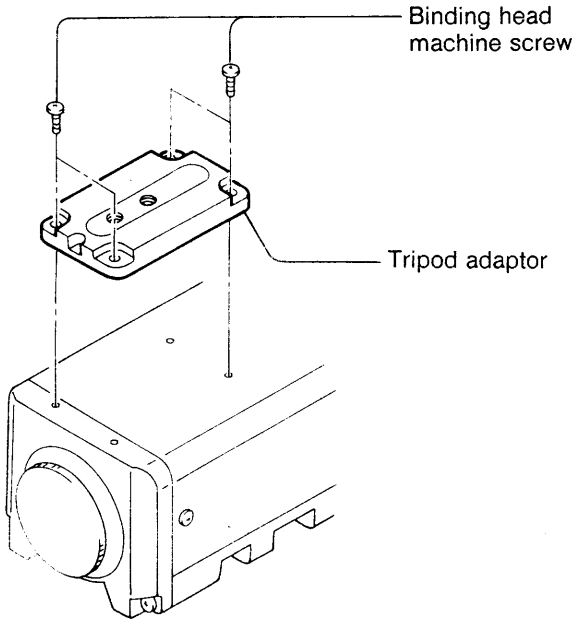

Caution

Use a camera fixing screw as illustrated below.

U1/4-20
L = 4.5 to 7mm

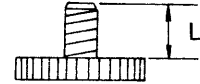

If a screw other than specified is used, the camera cannot be installed securely or may drop, resulting in damage.

Description on setting menus

Setting modes or values of the camera can be changed by using the corresponding setting menu displayed on a monitor screen.

The setting menus are configured as follows.

Configuration of setting menus

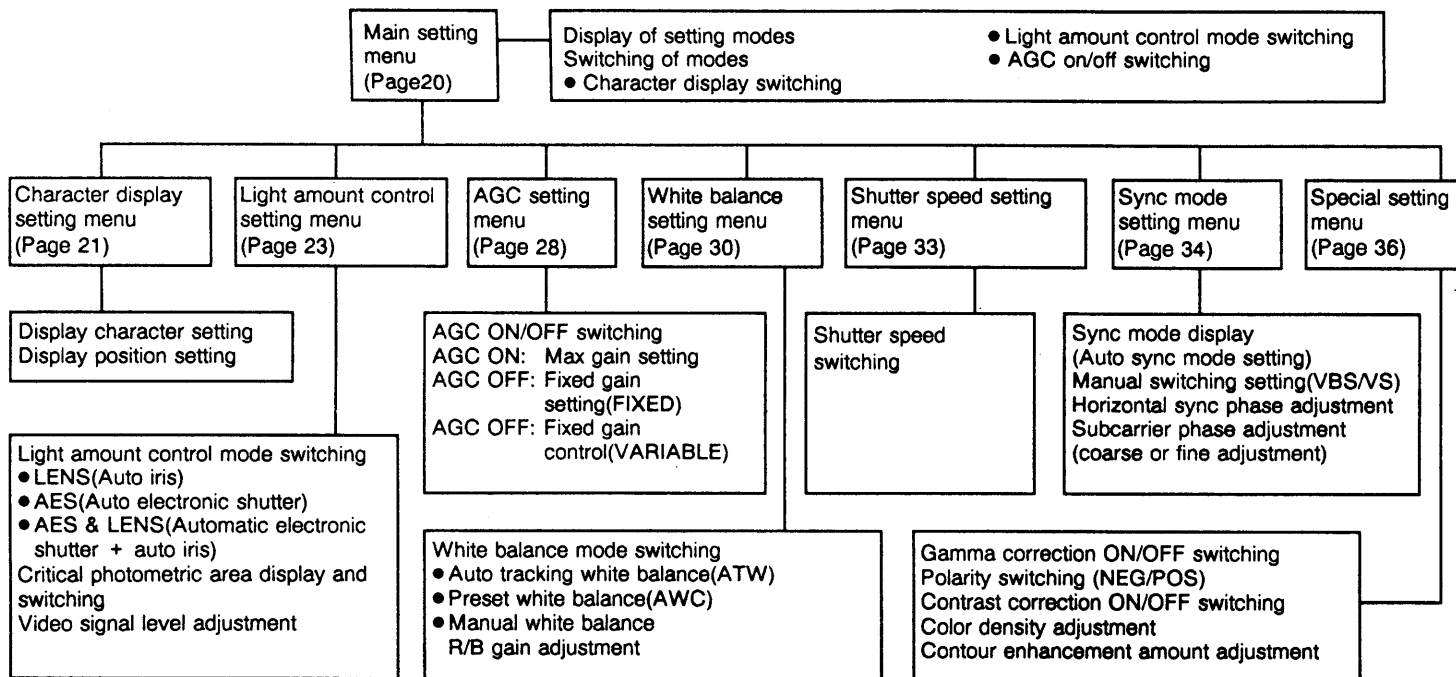

Setting procedures

Settings can be made by the five keys on the rear.

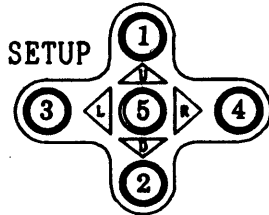

- ① △ switch : Press to move the cursor upward.
- ② ▽ switch : Press to move the cursor downward.
- ③ ◀ switch : Press to move the cursor leftward.
- ④ ▶ switch : Press to move the cursor rightward.
- ⑤ Setting switch: Press to display the main setting menu or to proceed to the next item after entering the set value.

Main setting menu

Note (KP-D50 only)

Characters are not displayed for the RGB output.

- 1) Press the setting switch more than 2 seconds, then the main setting menu (MAIN MENU) is displayed on the monitor.(Menus are not available from the RGB outputs.)

Cursor

```
<<<< MAIN MENU >>>>
>SET                :CLOSE      ..... Memory write CLOSE/OPEN(switchable)
TEXT DISPLAY       :ON          ..... Text character display ON/OFF(switchable)
LIGHT CONTROL     :LENS        ..... Light control mode(switchable)
AGC                :ON (21DB)   ..... AGC ON/OFF(switchable)
WHITE BALANCE     :ATW          ..... White balance setting mode display
SHUTTER SPEED     :1/60         ..... Shutter speed setting display
SYNC MODE         :INT          ..... Sync mode setting display
SPECIAL MENU      :             ..... Special setting menu
END                :             ..... End
```

Main setting menu

- 2) Confirm the current setting status on this menu screen.
- 3) If it is not needed to change any setting item, move the cursor to END at bottom left of the screen. Then press the setting switch to return to the normal shooting picture.

Caution:

The main setting menu will disappear if any key on the rear is pressed for approximately 5 minutes.

Storage of set data

- 1) Press the Δ or ∇ switch to move the cursor to **SET**.
- 2) Press the \blacktriangleright or \blacktriangleleft switch to change **CLOSE** at the right side of **SET** to **OPEN**.

```
<<<< MAIN MENU >>>>
>SET                :OPEN
TEXT DISPLAY       :ON
LIGHT CONTROL     :LENS
AGC                :ON (21DB)
WHITE BALANCE     :ATW
SHUTTER SPEED     :1/60
SYNC MODE         :INT
SPECIAL MENU      :
END
```

Main setting menu

Caution:

When the setting data is changed with **CLOSE** displayed, the data disappears at power-off and the previous data becomes effective at power-on.

3) Press the setting switch.

4) When the cursor is moved to the next item or when the setting switch is pressed after the setting status is changed, the changed data is stored to the memory (EEPROM) in the camera. When the camera is turned on, the stored data is effective.

Character display setting menu

Up to 24 characters (one line) can be displayed on the screen. Whether or not to display characters on the screen can be selected on the main setting menu.

Note(KP-D50 only)

Character can not be displayed on RGB outputs

- 1) Establish the memory write enable mode (**SET:OPEN**).
- 2) Move the cursor to **TEXT DISPLAY** by the ∇ switch.
- 3) Whether or not to display characters on the screen can be selected by the \triangleright or \triangleleft switch. (When characters are not set, they cannot be displayed.)
- 4) Change **OFF** after the **TEXT DISPLAY** item to **ON** by the \triangleleft or \triangleright switch.
- 5) Press the setting switch to display the text creation menu as shown on next page.

```

<< TEXT MENU >>

MODE  >ALPHA

1234567890→←↑↓/
ABCDEFGHIJKLMNQRST
UVWXYZI., &.:+AMPICH () -?

SPACE  ← →   RESET
LOCATE  RET   END
IF FRONT .....

```

- Character display mode(switchable)
- Character selection section
- Space/cursor movement(left/right)/Reset
- Text display position/Return/End
- Input character display position

Text setting menu(ALPHA)

Functions of each display above input character display position

SPACE: Move the blinking cursor to this position and press the setting switch. Then, a blank space is set.

← →: Use these arrows to change a display character.

- 1) Move the blinking cursor to the desired arrow, and press the setting switch. Then, the blinking cursor in the input character display area moves to the corresponding direction.
- 2) Press the setting switch until the blinking cursor reaches the desired character position.

- 3) Move the blinking cursor to the character to be inserted by the four arrow switches, and press the setting switch. The character in the input character display area is thus changed.

RESET : To erase all the characters in the input character display area, move the blinking cursor to **RESET**, and press the setting switch.

After the characters are erased, the blinking cursor returns to the beginning of the input character selection section.

RET : To return to the **MAIN MENU** from the **TEXT MENU**, move the blinking cursor to **RET**, and press the setting switch.

END : To return to the normal shooting picture from the **MAIN MENU**, move the blinking cursor to **END**, and press the setting switch.

LOCATE: Use this function to determine the display position of setting contents.

- 1) Move the blinking cursor to **LOCATE** and press the setting switch. Then, the contents of text are displayed.
- 2) Move the text to the desired position by the four arrow switches. When the text comes

to the end of the screen, it stops.

- 3) Press the setting switch when the text comes to the desired position. Then, the main setting menu appears.

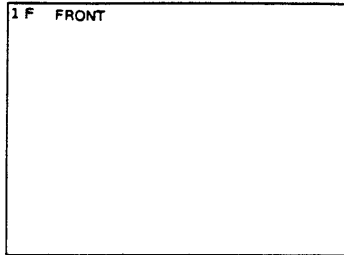

Move the text to the desired position by the four arrow switches, and press the setting switch.

Text display screen(LOCATE)

Light control setting menu

- 1) Press the setting switch for more than 2 seconds, then the main setting menu is displayed on the monitor.
- 2) To store the set contents, move the cursor to **SET** by the Δ or ∇ switch.
- 3) Change **CLOSE** to **OPEN** by the \triangleleft or \triangleright switch, and press the setting switch.
- 4) Move the cursor to **LIGHT CONTROL** and press the setting switch. Then, the LIGHT CONTROL MENU screen is displayed.

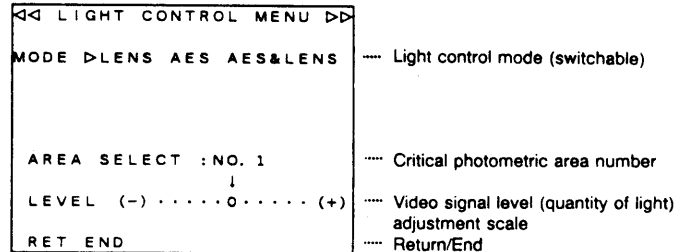

Light control menu

Three control modes are available in combination with the AGC operation.

The LENS mode is established at factory. To change the LENS mode to other mode, move the cursor to the desired control mode by the ◀ or ▶ switch, and press the setting switch.

To use the LENS mode, move the cursor to **LENS**, and press the setting switch.

① **LENS mode:**

In this mode, quantity of light can be controlled only by the lens iris.

② **AES mode:**

In this mode, quantity of light can be controlled only by the automatic electronic shutter of the CCD imaging device.

An optimum video signal level is maintained for a fixed iris lens.

When an auto iris lens is used, the lens iris is automatically opened to a maximum, and only the automatic electronic shutter operates.

A shutter speed is selectable from the standard (1/60s) to 1/10,000s.

Therefore, the automatic electronic shutter operates under the illumination condition within the range of 160 times, compared with the quantity of light, and this mode may not be effective in the outdoors where

illumination changes largely. In such cases, change to other mode.

When the lens iris is opened to a maximum in this mode, the depth of focus may become shorter than the auto iris lens used in other mode, and objects in the distance are out of focus. The depth of focus is in inverse proportion to the opening of a lens iris.

When an automatic electronic shutter is activated, the following phenomena may be observed. In such cases, change to other mode.

- Strong smear or blooming is observed when objects are illuminated by strong illumination like a spot light.
- Flickers or change in color are observed on the screen.

③ **AES & LENS mode:**

In this mode, the automatic electronic shutter operation has priority to control the quantity of light.

When illumination becomes bright, automatic electronic shutter control is performed from the standard (1/60s) to the set shutter speed with the lens iris opened to a maximum.

When illumination becomes brighter, the shutter speed is fixed to the set shutter speed, and the quantity of light is controlled only by the lens iris.

When illumination becomes dark gradually, the

quantity of light is controlled by the inverse operation.

```
<< LIGHT CONTROL MENU >>
MODE  LENS  AES>AES&LENS  ..... Automatic electronic shutter + lens iris
                                     >1/1000SEC      mode
                                     ·1/2000SEC
                                     ·1/4000SEC
Limit shutter speed (switchable)

AREA SELECT : NO. 1
              ↓
LEVEL (-) ······ 0 ······ (+)

RET END
```

Light control menu

Photometric area setting screen

The standard area No.1 is set at factory. When the setting switch is pressed while "No.1" is blinking, the critical photometric area is displayed. The critical photometric area is indicated by dots. When this area is changed, a video signal level is changed according to the illumination of this area.

The desired photometric area can be selected from among the areas No.1 thru No.8.

Therefore, select the photometric area so that the optimum video signal level can be obtained.

When the setting switch is pressed with the desired photometric area displayed, the video signal level adjustment scale appears.

Backlight correction

When strong backlight enters the lens, the lens iris closes accordingly, and the other objects become dark.

The backlight correction function is provided for this camera. With this function, the signal level for such a strong backlight is automatically corrected, and the other objects do not become dark.

When strong light enters the upper half portion of the critical photometric area No.1 with the photometric area set to No.1, the backlight correction function is activated automatically. The backlight correction function is activated in any light control mode.

When strong light enters the critical photometric area, effective backlight correction is performed by selecting a photometric area far from the position of strong light. If video signal level is not appropriate when the backlight correction function is being activated, adjust the video signal level.

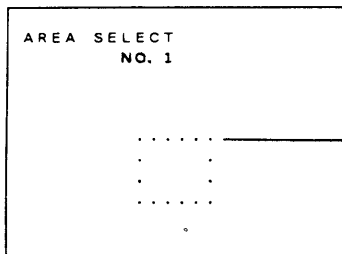

..... Critical photometric area selected
 Area number display

Critical photometric area display

Critical photometric area display (1)

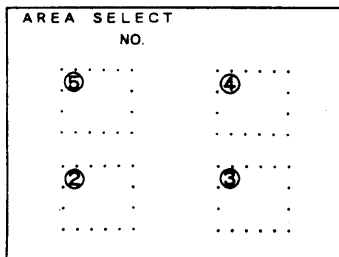

Critical photometric positions Nos. 2 to 5

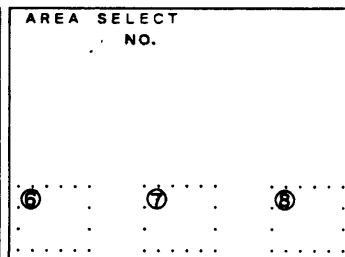

Critical photometric positions Nos. 6 to 8

Video signal level setting menu

The video signal level is set to the standard at factory. To adjust the video signal level, move the cursor to the desired level by the ◀ or ▶ switch, and press the setting switch.

When it is not needed to change the standard setting, press the setting switch, then the cursor moves to RET.

Select the AES & LENS mode and press the setting switch. Then, the cursor blinks at "1/1000 SEC". The shutter speed of an automatic electronic shutter is set to 1/1000 seconds at factory.

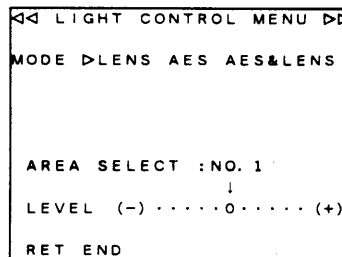

..... Light control mode(switchable)

..... Critical photometric area number display

..... Video signal level (quantity of light) adjustment scale

..... Return/End

Light control menu

When it is not needed to change a shutter speed

1) Press the setting switch.

When it is needed to change a shutter speed

- 1) Move the cursor to the desired shutter speed, and press the setting switch.
- 2) Move the blinking cursor to **RET** by the ◀ or ▶ switch, and press the setting switch. Then, the main setting menu appears.
- 3) Allow **END** to blink, and press the setting switch. Then, the normal shooting picture is displayed.

AGC setting menu

- 1) Press the setting switch for more than 2 seconds. Then, the main setting menu is displayed.
- 2) To store the set contents, move the cursor to **SET** by the Δ or ∇ switch.
- 3) Change **CLOSE** to **OPEN** by the \triangleleft or \triangleright switch, and press the setting switch.
- 4) Move the cursor to **AGC MENU**, and press the setting switch. Then, the AGC setting menu (**AGC MENU**) is displayed.

With the AGC setting menu, the AGC ON mode or the AGC OFF mode is selectable.

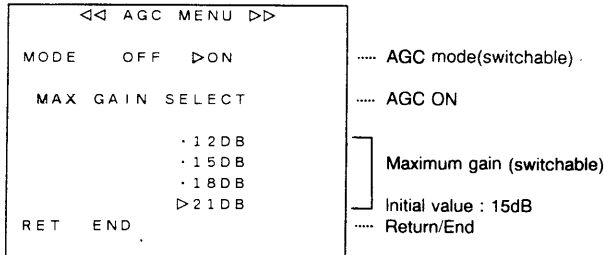

AGC setting menu

AGC ON mode setting menu

The AGC mode is set to the ON mode at factory, and the maximum amplification degree of AGC circuit is + 15dB.

Change of maximum amplification degree

- 1) Press the setting switch when the cursor at the left side of **ON** is blinking. Then, the cursor at the MAX GAIN SELECT section blinks.
- 2) Move the cursor to the desired amplification value, and press the setting switch.

Caution: When the maximum amplification degree is set to a higher value, sensitivity is increased, but noise may be increased for dark scene.

AGC OFF mode setting menu

In the AGC OFF mode, amplification degree is fixed.

- 1) Move the cursor to **OFF** on the AGC setting menu by the \triangleleft or \triangleright switch, and press the setting switch. Then, the amplification degree selection screen is displayed.

```

<< AGC MENU >>
MODE  ▷OFF  ON
GAIN SELECT
▷FIXED  VARIABLE
▷ 0DB
  3DB
  6DB  ↓
 12DB (-) ..... (+)
RET  END

```

..... AGC OFF
 Fixed gain setting mode
 Fixed gain

AGC setting menu

- 2) To select the desired amplification degree, press the setting switch when the cursor is at the **FIXED** position.
- 3) Move the cursor to the desired value by the Δ or ∇ switch, and press the setting switch.

Fine adjustment of each gain

- 1) Move the cursor to **VARIABLE**, and press the setting switch.

```

<< AGC MENU >>
MODE  ▷OFF  ON
GAIN SELECT
FIXED ▷VARIABLE
  0DB
  3DB
  6DB  ↓
 12DB (-) ..... (+)
RET  END

```

..... Fixed gain:Fine adjustment
 Fixed gain :Adjustment scale

AGC setting menu(AGC OFF)

- 2) Adjust an amplification degree by the \triangleleft or \triangleright switch, and press the setting switch.
- 3) Allow **RET** to blink, and press the setting switch. Then, the main setting menu is displayed.
- 4) Move the blinking cursor to **END**, and press the setting switch. Then, the normal shooting picture is displayed.

White balance control setting menu

- 1) Press the setting switch for more than 2 seconds. Then, the main setting menu is displayed.
- 2) To store the set contents, move the cursor to **SET** by the \triangle or ∇ switch, change **CLOSE** to **OPEN** by the \triangleleft or \triangleright switch, and press the setting switch.
- 3) Move the cursor to **WHITE BALANCE**, and press the setting switch. Then, the white balance setting menu (**WHITE BALANCE MENU**) is displayed.

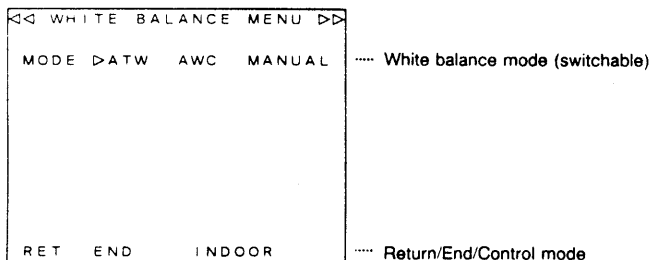

White balance setting menu

Three white balance control models are available.

1. Auto tracking white balance mode
2. Preset white balance mode
3. Manual white balance mode

1. Auto tracking white balance mode (ATW)

The white balance mode is set to the auto tracking white balance mode at factory.

Press the setting switch when the cursor is at **ATW**.

When **INDOOR** is displayed in this mode or the preset white balance mode, white balance is automatically controlled for the color temperature of illumination in the range from 2500K to 8000K.

In most cases, this mode can be used. When **OUTDOOR** is displayed, white balance is automatically controlled for the color temperature ranging from 5000K to 8000K.

Use the **OUTDOOR** setting when the camera is used outdoors. In case of the **OUTDOOR** setting, loss of white balance due to pale red or yellow is prevented.

Caution: To select **OUTDOOR**, turn off the camera, and turn on the camera again while pressing the \triangle switch.

To return to **INDOOR**, turn on the camera again, while pressing the ∇ switch.

Notes: In the following cases, adjust white balance manually, because ATW may not operate appropriately.

- Most of the screen is covered by the same color or white portion is excessively small.
- Objects are illuminated by plural lamps of different color temperatures.
- When special lamps like a sodium lamp are used.
- Background color is blue or red.

2. Preset white balance mode (AWC)

- 1) Move the cursor to AWC by the ◀ or ▶ switch and press the setting switch. Then, SET AWC starts to blink.

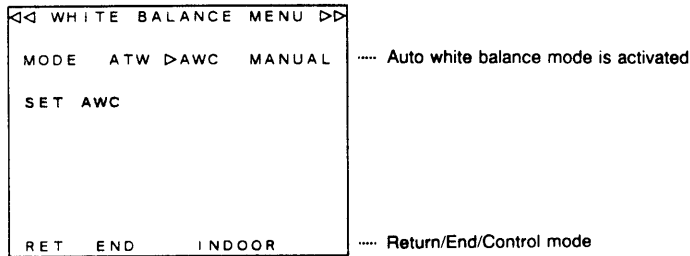

White balance setting menu

- 2) Allow white objects to be displayed under the illumination, and press the setting switch. Then, auto setting of white balance starts. When auto setting ends, SET AWC disappears and the white balance setting is fixed.

The time needed for auto setting depends on the condition. If it exceeds 10 seconds, take the following procedure.

- (1) Move the cursor to MODE ATW by the △ or ▽ switch.
- (2) Move the cursor to AWC, and press the setting switch.

- 3) Display white objects largely, and adjust white balance.

When this setting is performed with the SET on the main setting menu set to OPEN, the set data is retained after power off.

3. Manual white balance mode (MANUAL)

- 1) Move the cursor to MANUAL by the ◀ or ▶ switch, and press the setting switch. Then, the adjustment scale for R GAIN and B GAIN are displayed. The respective cursors are at the zero positions.

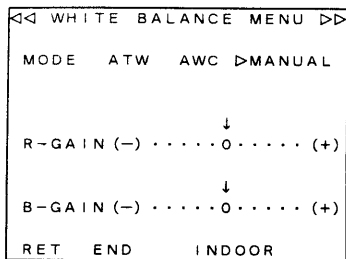

White balance setting menu

- 2) When the cursor of R GAIN blinks, adjust the amplification degree of red by the ◀ or ▶ switch, and press the setting switch to fix the adjusted value.
- 3) In a similar fashion, fix the adjusted value of blue.
- 4) If further adjustment is needed for red, allow the red adjustment scale to blink by the △ or ▽ switch, and take the same step as 3).
- 5) When adjustment ends, press the setting switch to allow **RET** to blink. Then, press the setting switch to return to the main setting menu.
- 6) Move the blinking position to **END** by the ◀ or ▶ switch, and press the setting switch. Then, the normal shooting picture is displayed.

Shutter speed setting menu

- 1) Press the setting switch for more than 2 seconds. Then, the main setting menu is displayed. When **LIGHT CONTROL : LENS** is displayed in the third line, a shutter speed can be set. In other mode, a shutter speed is controlled automatically and cannot be set optionally.

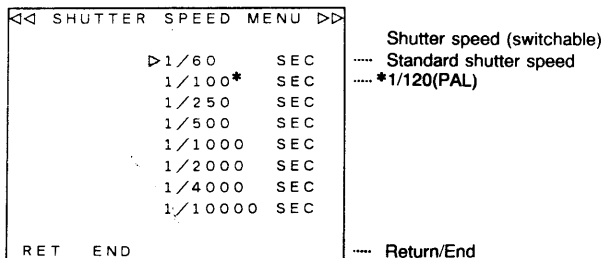

Shutter speed setting menu

Storage of the set contents

- (1) Move the cursor to **SET** by the \triangle or ∇ switch.
- (2) Change **CLOSE** to **OPEN** by the \triangleleft or \triangleright switch, and press the setting switch.

- 2) Move the cursor to **SHUTTER SPEED MENU**, and press the setting switch. Then, the shutter speed setting menu is displayed.
- 3) Move the cursor to the desired value, and press the setting switch.
- 4) Move the blinking position to **END** by the \triangleleft or \triangleright switch, and press the setting switch. Then, the normal shooting picture is displayed.

Sync mode (phase adjustment) setting menu

Storage of set contents

- 1) Move the cursor to **SET** by the \triangle or ∇ switch .
- 2) Change **CLOSE** to **OPEN** by the \triangleleft or \triangleright switch, and press the setting switch.
- 3) Move the cursor to **SYNC MODE MENU**, and press the setting switch. Then, the sync mode setting menu (**SYNC MODE MENU**) is displayed.

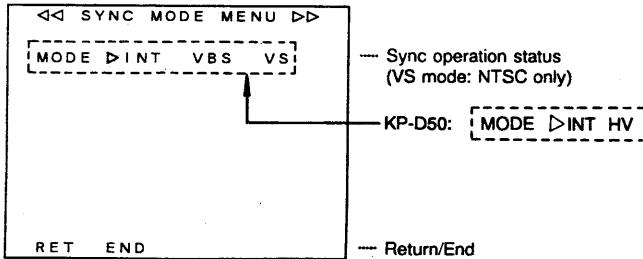

Sync mode setting menu

A composite color video signal, a black burst signal (VBS), a composite video signal or a composite sync signal can be connected to the camera as an external sync signal.

In case of the KP-D50, HD and VD signals can be connected.

Internal sync mode or external sync mode is switched automatically.

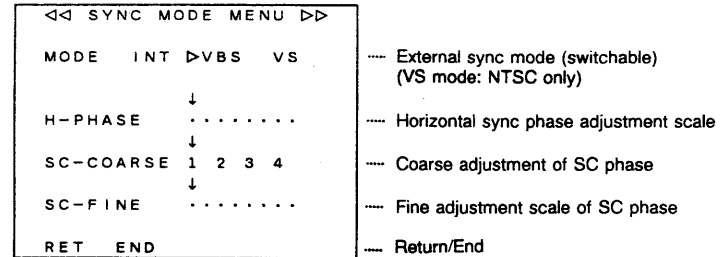

Sync mode setting menu (VBS)

When an external sync signal is connected to the camera, the cursor before **INT** moves to **VBS**.

- 1) When the VBS signal including a color subcarrier is connected, press the setting switch.
- 2) When the VS signal is connected, press the \triangleright switch to move the cursor to **VS**, and press the setting switch.

In case of the KP-D50

When the HD/VD signals are connected, the cursor moves to HV. Then, press the setting switch.

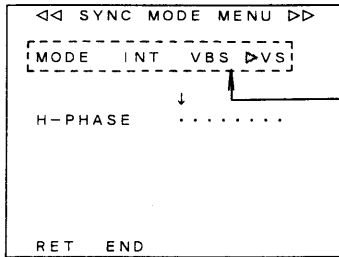

..... External VS signal (switchable)
 (VS mode: NTSC only)
 KP-D50: [MODE INT HV]
 Horizontal sync phase adjustment scale

Sync mode setting menu (VS)

- 3) The cursor for the phase adjustment (**H-PHASE**) of a horizontal sync signal blinks.
 Press the ◀ or ▶ switch, and adjust so that the phase of the external sync signal coincides with that of the video signal, using an oscilloscope. Then, press the setting switch.
 Adjustable range is 0 to 4μs.
- 4) The cursor for the coarse adjustment (**SC COARSE**) of the subcarrier phase blinks.
 Press the ◀ or ▶ switch, and adjust so that the phase of the external sync signal coincides with that of the subcarrier of the video signal, using a vectorscope. Then, press the setting switch.
 Adjustment is performed in 90° steps.
- 5) The cursor for the fine adjustment (**SC FINE**) of the subcarrier phase blinks. Press the ◀ or ▶ switch,

and adjust so that the phase of the external sync signal coincides with that of the subcarrier of the video signal, using the vectorscope. Then, press the setting switch. Adjustment is performed up to 90 degrees. If adjustment is insufficient, press the Δ switch to allow the cursor for the coarse adjustment (**SC COARSE**) of the subcarrier phase to blink, and press the ◀ or ▶ switch. Then, perform the adjustment again.

- 6) When the VS signal (the HD/VD signals for the KP-D50) is connected, adjust the horizontal sync signal only.
- 7) Allow **RET** to blink, and press the setting switch. Then, the main setting menu is displayed.
- 8) Press the ◀ or ▶ switch to move the blinking position to **END**, and press the setting switch. Then, the normal shooting picture is displayed.

Special setting menu

To change the settings related to the picture quality according to a specific application, use this menu.

<<< SPECIAL MENU >>>		
> GAMMA	: ON Gamma correction ON/OFF
Y/C INVERT	: POSITIVE Video signal polarity POS/NEG
CONTRAST	: OFF Contrast correction ON/OFF
COLOR	↓	
SATURATION 0 Color level adjustment scale
	↓	
PEDESTAL 0 Black level adjustment scale
	↓	
ENHANCER 0 Contour enhancer adjustment scale
RET END	(-) (+) Return/End

Special setting menu

- 1) Press the setting switch for more than 2 seconds.
Then, the main setting menu is displayed.

Storage of set contents

- 1) Move the cursor to **SET** by the \triangle or ∇ switch.
- 2) Change **CLOSE** to **OPEN** by the \triangleleft or \triangleright switch.
- 3) Move the cursor to **SPECIAL MENU**, and press the setting switch. Then, the special setting menu (**SPECIAL MENU**) is displayed.

• Gamma correction function setting (GAMMA)

When this camera is used in an image processing system, set the gamma correction function to **OFF**. Then, a video signal proportional to the brightness of objects is obtained. In this case, the picture displayed on a video monitor becomes rather dark. This function is set to **ON** when the CONTRAST correction function in the third line is set to **ON**.

• Picture polarity setting (Y/C INVERT)

Normally, a positive picture is displayed on the screen.

Set to **NEGATIVE** to display a positive picture when shooting a negative film illuminated from behind.

Note (KP-D50 only)

When the normal RGB output is inverted, a normal picture is not obtained. Use the RGB signals of positive polarity.

• Contrast correction function setting (CONTRAST)

Normally, this function is set to **OFF**.

When backlight is intense and objects are displayed dark, set this function to **ON**. Then, the dark objects are displayed bright, and high luminance portion is compressed, resulting in a natural picture.

When this function is set to **ON**, the gamma correction function is also set to **ON**.

When this function is set to **ON** with the photometric area set to No.1, this function is automatically set to **OFF** when intense backlight disappears. When intense light appears again, this function is automatically set to **ON**.

When a photometric area is set to the area other than No.1, this function is fixed to **ON** or **OFF** as set on this menu.

Note (KP-D50 only)

Set this function to **ON** in the RGB output mode. When it is set to **OFF**, a normal picture cannot be obtained.

● **Color saturation setting (COLOR SATURATION)**

Color saturation is set to **0** at factory.

To change color saturation, press the ◀ or ▶ switch.

Note (KP-D50 only)

In the RGB output mode, use the camera with this scale set to 0 (value set at factory). If this setting is changed in the RGB output mode, a normal picture is not obtained.

● **Black level setting (PEDESTAL)**

Black level is set to the optimum value at factory.

To change black level, press the ◀ or ▶ switch.

Note (KP-D50 only)

In the RGB output mode, use the camera with this scale set to 0 (value set at factory). If this setting is changed in the RGB output mode, a normal picture is not obtained.

● **Contour enhancer setting (ENHANCER)**

Contour enhancer is set to **0** at factory.

To change contour enhancement amount, press the ◀ or ▶ switch.

● **RET and END**

Allow **RET** to blink, and press the setting switch. Then, the main setting menu is displayed.

Press the ◀ or ▶ switch to move the blinking cursor to **END**, and press the setting switch. Then, the normal shooting picture is displayed.

Color temperature and white balance adjustment

A color temperature expresses one of the natures of light. Its unit is Kelvin (K), and 0K corresponds to -273°C .

For color temperatures, illuminations and weather conditions, see the chart at right.

A color temperature is not related to brightness. When a color temperature becomes higher, color becomes bluer. When a color temperature becomes lower, color becomes redder.

Our eyes have adaptability to the color of light, and we do not sense the change in hue even when illumination changes. However, a TV camera senses the change in color temperature faithfully, and the hue of the displayed picture is different from the hue we sense. To correct such difference of color temperatures, white balance correction is required.

In case of this camera, three kinds of white balance correction are available. (See page 30.)

Color temperature, illuminations and weather conditions

Color temp. (K)	Weather condition	Illumination
10,000	Fine blue sky	Xenon arc
8,000	Twilight	
7,000	Cloudy sky Bright rainy day Daylight	
5,000	Midday sunlight 2 hours after sunrise	Fluorescent lamp
4,000		
3,500	1 hour after sunrise	Halogen lamp Iodine lamp 100 to 500W gass-filled lamp 100W tungsten lamp
3,000		
2,500		600W tungsten lamp
2,000	Around sunrise	
		Candle light

Remote operation

The menu setting switches on the rear can be remotely controlled.

- 1) Connect wires to the optional remote plug as shown below.
- 2) Connect the remote plug to the connector on the rear.

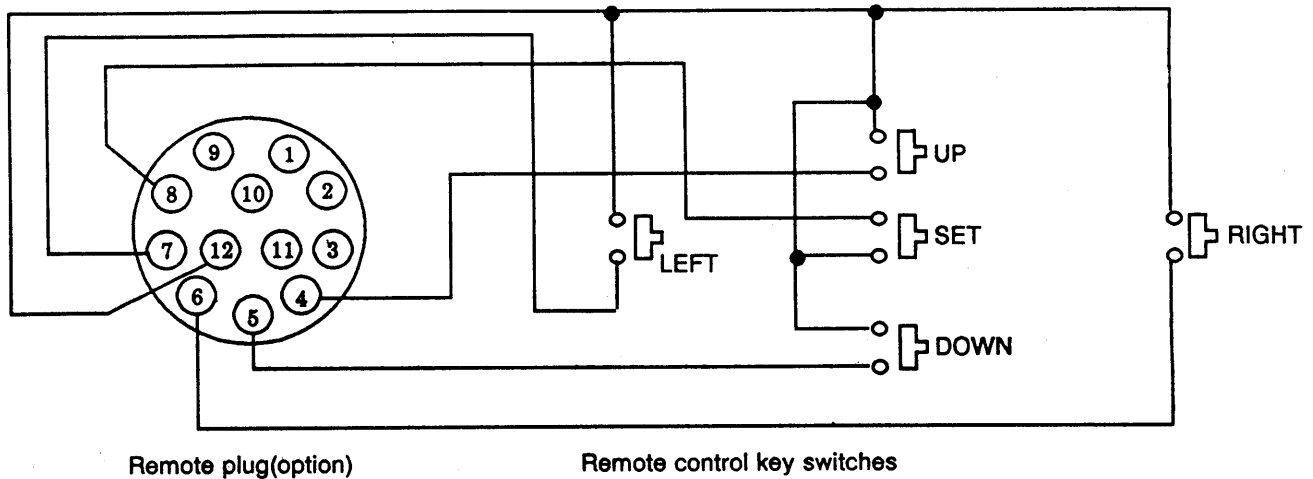



Pin No.	Signal name		Abbreviation	Remark
1	KP-D51	Remote mode selector input	REM	When this signal is connect to GND, key switches become null.
	KP-D50	Not connected	N. C.	
2*	Serial data (+) input		COM +	Connect to the data terminal of RS-232C.
3*	GND < serial data (-) input >		COM-	connect to GND of RS-232C
4	△ key input		UP	
5	▽ key input		DOWN	
6	▷ key input		RIGHT	
7	◁ key input		LEFT	
8	Setting key input		SET	
9	GND		GND	KP-D51 only (Not connected for KP-D50)
10	Ext. sync signal input		GL IN	
11	N. C.		N. C.	
12	L + 5V output for key switches		L + 5V	Power supply dedicated to remote key switches

Note: * To perform the remote control by connecting the serial data, the software are for camera setting data transmission is required.

Major specifications

1. Color system	NTSC/PAL
2. Imaging device	Interline transfer type CCD
No. of pixels	NTSC: 811(H) × 508(V) PAL: 795(H) × 596(V)
No. of effective pixels	NTSC: 768(H) × 494(V) PAL: 752(H) × 582(V)
Sensing area	NTSC: 7.55(H) × 6.45(V)mm PAL: 7.95(H) × 6.45(V)mm
Size of cell	NTSC: 8.4(H) × 9.8(V)μm PAL: 8.6(H) × 8.3(V)μm
3. Scanning system	2:1 interlaced
4. Scanning frequency	Hor. NTSC: 15.734kHz PAL: 15.625kHz Vert. NTSC: 59.94Hz PAL: 50Hz
5. Sync system	Internal/external (automatic switching)
6. Signal processing system	Digital processing (only for internal processing) Input : 9 bits Output : 8 bits
7. Output signals	VBS 1.0Vp-p/75 ohms Positive or negative (switchable) Sync : Negative

KP-D50

8. Ext. sync input

KP-D51

KP-D50

9. Resolution

KP-D51/50

RGB outputs

RGB: 1.0Vp-p/75 ohms, positive
Sync(G signal only):0.3Vp-p, negative, ON-OFF switch

Y/C outputs

Y:1.0Vp-p/75 ohms
Video: 0.7Vp-p, positive
Sync: 0.3Vp-p, negative, ON-OFF switch

C:0.3Vp-p (burst)/75 ohms

Sync output:

4.0Vp-p/75 ohms, negative

Black burst or VBS

SYNC: 0.3Vp-p/75 ohms
Burst: 0.3Vp-p/75 ohms
Video: 0.7Vp-p or less/
75 ohms
(fsc = 3.579545MHz)

75-ohm ON/OFF switch

Ext. HD/VD

HD:4.0Vp-p/75 ohms
VD:4.0Vp-p/75 ohms

Hor.

NTSC: 470 TV lines (Y signal)



	<p>PAL: 460 TV lines (Ysignal) Vert. NTSC/PAL:350 TV lines (Y signal) Primary colors Hor.:90 TV lines at center Vert.:130 TV lines at center Common to NTSC/PAL</p>		
KP-D50			
10. Signal-to-noise ratio (Y signal)	50dB (KP-D51)/48dB (KP-D50) or more (AGC:OFF, no contour correction, no gamma correction) 48dB (KP-D51)/46dB (KP-D50) or more (AGC:OFF, contour correction:ON, gamma correction:ON)	15. Output for ES lens	(1) Video signal input type lens Y signal:1.0Vp-p/high impedance Power supply:12VDC, 60mA (KP-D51)/40mA (KP-D50) or less (2) Iris control voltage input type lens Damping coil:1150Ω ± 10% Drive coil:190Ω ± 10%
11. Minimum illumination	2 lx (f1.2, 3200K, AGC:ON)	16. Backlight correction	Auto correction mode/ manual setting mode
12. Illumination range	2 to 100,000 lx (auto iris lens)	17. Automatic electronic shutter	Tracking illumination range:2000 lx or less (f1.4, AGC:ON, fixed iris lens)
13. Gain	AGC ON/OFF switchable Fixed gain settable	18. Electronic shutter	1/60 NTSC (1/50 PAL), 1/100 NTSC (1/120 PAL), 1/250, 1/500, 1/1000, 1/2000, 1/4000, 1/10,000 s
14. White balance	Auto tracking white balance (ATW), preset white balance (AWC) or manual control	19. Character display	24 characters (alphanumerics and symbols)
		20. Lens mount	C-/CS-mount

21. Ambient conditions -10 to 50°C, 95% RH or less

CAUTION:

When the camera is used continuously for a long time, be sure to use it at less than 40°C to ensure stable performance.

22. Storage conditions -20 to 60°C, 95% RH or less

23. Power supply

KP-D51

U type: 120V AC \pm 10% 60Hz

E type: 230V AC \pm 10% 50Hz

K type: 230V AC \pm 10% 50Hz

KP-D50

12 \pm 0.5V DC

24. Power consumption

5.7W (KP-D51)/410mA

including auto iris lens (KP-D50) approx.

25. Dimensions

KP-D51

64(W) \times 55(H) \times 178(D)mm

KP-D50

64(W) \times 55(H) \times 122(D)mm

26. Mass

600g (KP-D51)/400g (KP-D50) approx.

Accessories

Lens plug, E4-191-100	1
Fuse*, U type: 125V, 630mA	1 (KP-D51 only)
E/K type: 250V, 400mA	1
DC power plug, R03-P3F	1 (KP-D50 only)
Operation manual	1

* Caution (KP-D51 only)

A fuse must be replaced only by qualified service personnel.

• Optional accessories

Camera mount adaptor, TA-231

Lenses (See page 12.)

Remote plug, HR10A-10P-12P (01)

RGB output plug (For KP-D50)



HITACHI DENSHI, LTD.

1, Kanda Izumi-cho Chiyoda-ku, Tokyo 101, Japan
Phone : (03) 5821-5311, FAX : (03)5821-5394

HITACHI DENSHI AMERICA, LTD.*

Headquarters and New York Office

150 Crossways Park Drive, Woodbury, New York 11797, U. S. A.
Phone : (516) 921-0993, FAX : 516-496-3718, Telex : 510-221-1899

Chicago Office

250 East Devon Ave., Suite 115 Itasca, Illinois 60143, U. S. A.
Phone : (708) 250-8050 FAX : 708-250-8054

Los Angeles Office

371 Van Ness Way, Suite 120 Torrance, CA, 90501, U. S. A.
Phone : (310) 328-6116, FAX : 310-328-6252

Dallas Office

2100 West N. W. Highway Suite 1145 Grapevine, TEXAS 76051, U. S. A.
Phone : (817) 488-4528, FAX : (817) 488-4714

Atlanta Office

3039 Amwiler Road, Suite 118 Atlanta, Georgia 30360, U. S. A
Phone : (770) 242-3636, FAX : 770-263-8838

HITACHI DENSHI, LTD. (CANADA)*

Head Office

65 Melford Drive, Scarborough, Ontario M1B 2G6, Canada
Phone : (416) 299-5900, FAX : (416) 299-0450, Telex : 652-5324

Eastern Office

8100 H Trans Canadienne, St Laurent, Quebec, H4S 1M5, Canada
Phone : (514) 332-6687, FAX : (514) 335-1664, Telex : 582-4768

Ottawa Office

9 Antares Drive, Nepean, Ontario, K2E 7V5, Canada
Phone : (613) 727-3930, FAX : (613) 727-3955

HITACHI DENSHI (EUROPA) GmbH*

Head Office

Wesikircher Strabe 88, D-63110 Rodgau, Germany
Phone : (6106) 6992-0, FAX : (6106) 1690-6, Telex : 417-849

HITACHI DENSHI (U. K.) LTD.*

Head Office

14 Garrick Industrial Centre, Irving Way, Hendon , London NW9 6AQ,
United Kingdom

Phone : (181) 202-4311, FAX :181-202-2451

Leeds Office

Brookfield House, Selby Road, Garforth, Leeds LS25 1NB United Kingdom
Phone : 113-287-4400, FAX : 113-287-4260

HITACHI DENSHI, LTD. BEIJING OFFICE

100004 Beijing Fortune Building
5, Dong San Huan Bei-LU, Chan Yang District,
Beijing, China
Phone : 501-4322/4323 FAX : 501-4324

Beijing Service Center

B19, Bei San Huan Middle Road Beijing China
Phone : 204-3901 FAX : 204-3902

HITACHI DENSHI, LTD. SINGAPORE BRANCH

10 Anson Road #20-15 international Plaza singapore 079903
phone : 65-223-0030, FAX : 65-223-0206

* Subsidiaries of Hitachi Denshi, Ltd.